



AUTOMATIC FIRE EXTINGUISHING SYSTEM for TUNNEL PROTECTION with REMOTE CONTROLLED MONITORS on OVERHEAD RAIL (TUDEM-CAR)

Generals

Innovating fire extinguishing system for tunnel fires, for fully automatic intervention or for remote operation from a remote Control Room.

The system is based on the proven technology of fire fighting remote controlled foam/water monitors, worldwide utilized and appreciated for the fire protection in heavy risk plants.



The fire extinguishing system for tunnel protection with mobile remote controlled monitors on overhead trailer consists in a fixed structure (overhead rail), installed at the ceiling along the tunnel, and in a number of mobile units (trailers) equipped with foam/water monitors moving along the fixed structure.





The fixed structure is equipped with:

- main water (or foam premix) supply pipe (working pressure ~10 bar),
- main electric power supply line,
- serial bus for data transmission,
- heat sensing cable and infrared flame detectors for fire detection.

At regular intervals (typically 42 meters) along the tunnel, docking and control stations are provided for stop and connection of the mobile units with monitor and start of the fire extinguishing operations.



Each mobile unit (trailer) is equipped with:

- the electric remote controlled fire fighting monitor with flow rate 1.000 lt./min.,
- the motors for the linear movement of the trailer along the overhead rail,
- the battery for power supply of the unit during the movement along the overhead rail (buffer batteries which are automatically charged when the unit is connected "in stand-by" to a docking and control station),
- 2 IP / TV cameras for visible and infrared light,
- the electric panel with command and control devices,
- (optionally) 1 flammable gas detector and 1 toxic gas detector for monitoring dangerous situations.

The fire protection system is integrated with a water pressurizing unit and with a foam proportioning system, consisting of a pumping station (normally with electric pump and Diesel motor pump) and a displacement liquid foam proportioner.

Alternatively to the displacement liquid foam proportioning unit, a balance pressure foam proportioner with related foam concentrate pump can be used.

The dimensioning of the foam storage and proportioning system depends on tunnel length and features.



Usually, for short and medium length tunnels, the same foam supply system can be used for the 2 barrel vaults of the tunnel or for 2 adjacent tunnels.



It is important to consider that the extinguishing system with fire hydrant cabinets as required by law can be easily integrated in the proposed automatic extinguishing system with remote controlled monitors.

The fire hydrant cabinets are directly connected to the monitors main water supply line with regular intervals of 126 or 252 meters (with a step multiple of the distance of the docking and control stations) and are usually equipped with a pressure reducing valve to reduce the water pressure at the manually operated branch pipes at about 4÷5 bar.

In this case the pumping station is additionally equipped with a jockey pump to maintain the main water supply line permanently at a pressure of 5 bar for the hydrant cabinets.

Automatic operation of the system

The automatic operation of the system is performed through a centralized main command and control panel installed in the Control Room of the tunnel or in any other technical room. For the automatic intervention, the extinguishing system is combined with a double technology fire detection system with linear heat detectors and infrared flame detectors installed along the whole length of the tunnel.

In case of detection of a fire, the two nearest mobile units with monitor (which, in stand-by condition, are positioned with constant step of about 800 m. along the tunnel) move along the rail and reach the docking and control stations closest to the fire zone.

The 2 monitors automatically connect to the main water (foam premix) supply line through a special patented coupling and start spraying water or foam with a step-less adjustable jet from full jet (for maximum throw and extinguishing power) to narrow cone and wide cone fog jet (for maximum cooling effect) as shown here below:

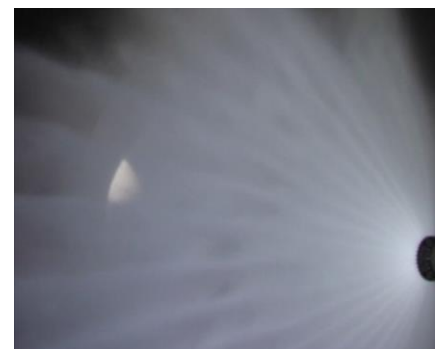

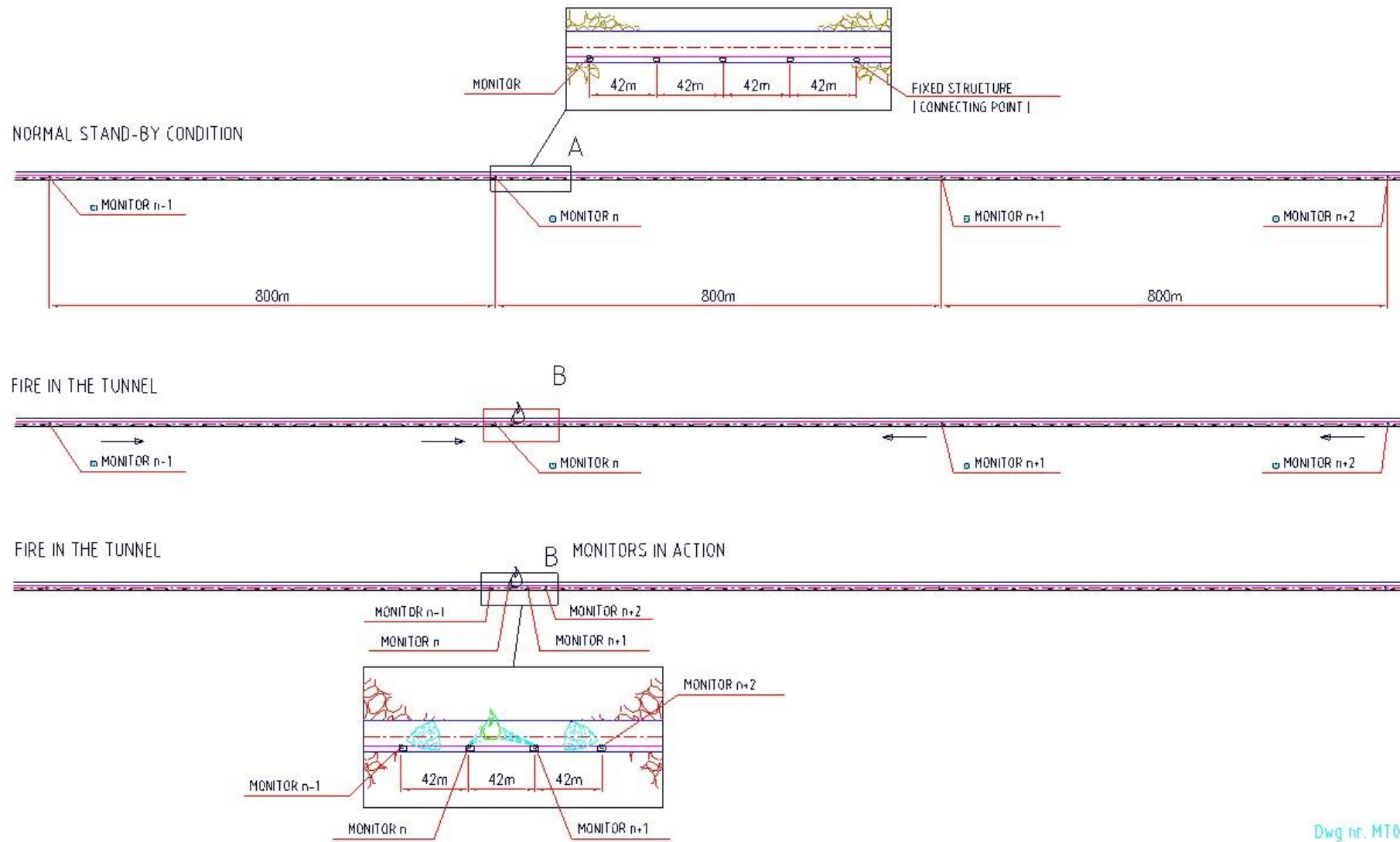

Typical system working process

Dwg. nr. MT001751



The connection of the mobile units to the coupling of the docking and control station automatically connect also the electric power supply and the data transmission between the mobile unit and the fixed system.

In case of longer tunnels with more than 2 mobile units, the two mobile units positioned immediately upstream and downstream the 2 units involved in the fire extinguishing intervention move to the next closer docking and control stations, connect to the feeding line and start spraying water with a wide cone fog jet (with spray angle 120°) with cooling effect to drop the temperature inside the tunnel and for containing the fire smoke.

The complete typical process is reported in the scheme on page 4, showing the monitors in "stand-by" position, their translation to the nearest docking and control stations in case of fire and their operation for the extinguishing intervention, for cooling the heat and for containing the smoke of the fire.

Manual remote control of the system with joy-sticks from the panel in the Control Room

From the main command and control panel in the Control Room it is possible to control the situation in the tunnel by means of high sensibility IP / TV cameras for visible and infrared light mounted on the mobile units, and to operate the monitors from remote with the joy-stick controller, aiming the jet of the monitors exactly on the fire.

This operation can be performed as final tuning of the automatic intervention of the system or on autonomous decision of the operator in the Control Room.

In this case it is sufficient to click with the mouse the exact point on the screen where the extinguishing operation is required in order to activate immediately the positioning procedure of the mobile units and their connection to the water supply line and to the electric power and signal transmission line.

Input	1	2	3	4	5	6	7	8	9	10	11	12	13	14	15	16
Output	Off	Off	Off	Off	Off	Off	Off	Off	On	On	On	On	Off	Off	Off	Off

ID	Detector Name	Status	Value	Unit
311	IR-Melder 1 auf CP #31	Enabled	[553 mA]	[0 mV]
312	Thermo-Melder 2 auf CP #31	Enabled	[540 mA]	[0 mV]
313	Thermo-Melder 3 auf CP #31	Enabled	[552 mA]	[0 mV]
314	Thermo-Melder 4 auf CP #31	Enabled	[562 mA]	[0 mV]
315	Thermo-Melder 5 auf CP #31	Enabled	[544 mA]	[0 mV]
316	IR-Melder 6 auf CP #31	Enabled	[540 mA]	[0 mV]
317	Temperat-Melder 7 auf CP #31	Disabled	[7 mA]	[0 mV]
318	Temperat-Melder 8 auf CP #31	Enabled	[594 mA]	[0 mV]

The IP / TV cameras for visible and infrared light on the mobile units allow the monitoring of the tunnel from the Control Room, with visible light or infrared technology depending on the local conditions and on the size of the objects to be observed.



Finally the system allows to best coordinate the operations of the fire brigades, showing continuously the situation of the fire area and of the surrounding.

Dimensioning of the system

Studies on the behaviour of fire development in tunnels performed by Research Institutes and Fire Brigades Laboratories are available in the literature, both supported by real tests and by mathematical models based on semi-empiric relations.

These studies, specially focussed on the time / temperature curves depending on the heating power of the different ignition sources, show that the maximum temperatures in a tunnel fire are reached after about 10 minutes, and that for the first 5 minutes the temperature inside the tunnel does not significantly differ from the temperatures reached by similar fires in open space.

When proper extinguishing actions start, the temperature increase stops almost immediately.

Following to the above, for tunnel fires an efficient extinguishing system must be activated in less than 5 minutes. Of course, above indicated parameters are average values, and the specific value for each single tunnel must be determined with a risk analysis.

The dimensioning of the automatic fire extinguishing system with remote controlled monitors for tunnels protection must consequently assure an intervention time of less than 4 minutes from the start of the fire to the beginning of the automatic extinguishing action.

A time of less than 2 minutes is considered for the fire detection and the validation procedures. The translation of the mobile units to reach the nearest docking station for connection to the water feeding line and start automatically the extinguishing operation requires less than 1 minute.

The translation speed of the mobile unit along the overhead rail is ≥ 10 m./sec.

Therefore, to assure that in less than 1 minute the monitors are activated and positioned and the extinguishing operation can start, the mutual distance of the single mobile units (trailer with monitor) in "stand-by" condition (when not working) is ≥ 500 m. up to maximum 1 km (typical step 800 m.).

In case of remote joy-stick operation of the system directly from the operator in the Control Room, the time of intervention can be further reduced.

Indeed, when the operator in the local or remote Control Room individuates a fire, he can immediately activate the extinguishing procedure (eliminating the time of automatic fire detection and validation), starting the extinguishing operation in less than 2 minutes.



The same happens if the operator decides to activate the extinguishing operation based on an alarm from a single fire detector, after checking the situation via the IP / TV cameras for visible and infrared light, without waiting for the redundant signal of the heat sensing cable (which is normally slower).

Structure of the system

An overhead rail (fixed structure) is installed at the ceiling along the tunnel, equipped with the main water (or foam premix) supply pipe, the main electric power supply line, the serial bus for data transmission and the heat sensing cable for fire detection as shown in the following picture.

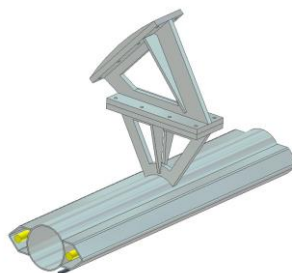

Fixed structure

Relevant for the system are the compact installation and the little space occupied along the tunnel vault.

The docking and control stations are mounted along the tunnel as shown in the following picture with a typical spacing of 42 m.

These points are the backbone of the fire detection sub-system, with regard both to the flame detectors (2 flame detectors mounted at each docking and control station, oriented to the 2 directions of the tunnel) and to the heat sensing cable, divided into different functional sections distributed along the tunnel.

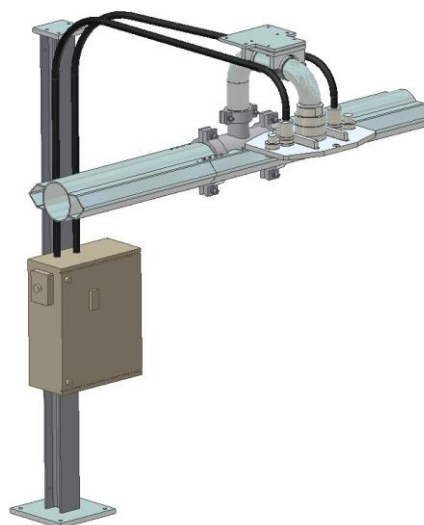

Docking and control station



The signals of the fire detectors are processed in protected wall-mounted panels installed along the tunnel in proximity of each docking and control station, where additional fixed monitoring cameras, both for visible and infrared light, can be interfaced if required.

The same panels also provide the power supply to the special connecting couplings of each docking and control station, where the mobile units (trailers with monitor) are connecting moving along the overhead rail.

The following picture shows the typical scheme of the mobile unit (without the protection hood).

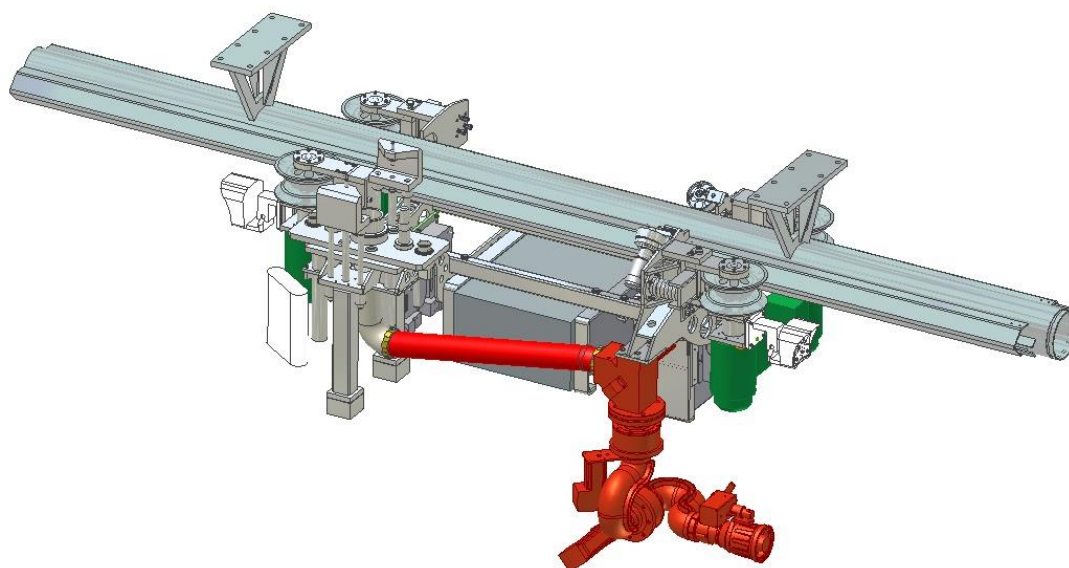

Mobile unit (trailer with monitor) without protection hood



Picture of the mobile unit (trailer with monitor) connected to a docking station



The mobile unit is equipped with the foam/water monitor (the biggest structure on the trailer), with the 2 IP / TV cameras for visible and infrared light, and with the eventual flammable gas detectors and toxic gas detectors.

The monitor is also equipped with a remote controlled on-off valve for start or stop of the water or foam stream.



The monitors are dimensioned for a specific water / foam flow rate of 1.000 lt./min. each, and following much higher than the total specific flow rate of any mobile unit or fixed spray system normally used for extinguishing operations inside tunnels.

The total water discharge of the remote controlled monitors system is nevertheless similar to the flow rate required for other fixed spray systems for tunnel protection, however this system allows to concentrate the full available water or foam stream exactly where required on the fire, instead of dispersing the extinguishing agent flow rate with uniform distribution along longer sections of the tunnel.

The scheme on page 10 shows the typical water distribution of the system, including also the fire hydrant cabinets as required by law.

The scheme on page 11 shows the typical electric and signal connections with the redundant double loop, to assure 100% functionality of the system in case of first failure in any point of the tunnel.

The below picture shows the panel installed in each docking and control station.

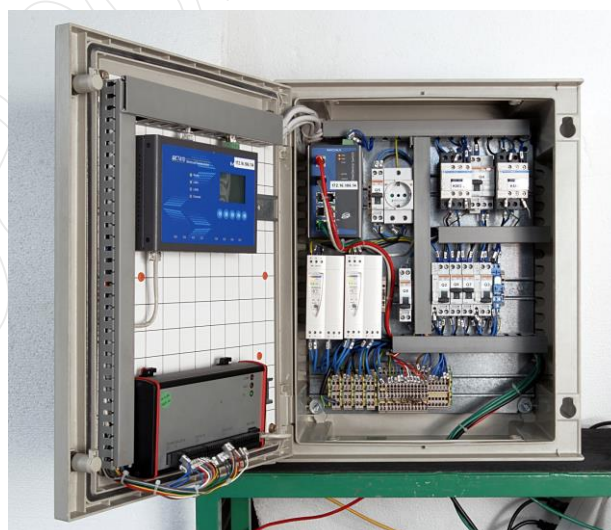

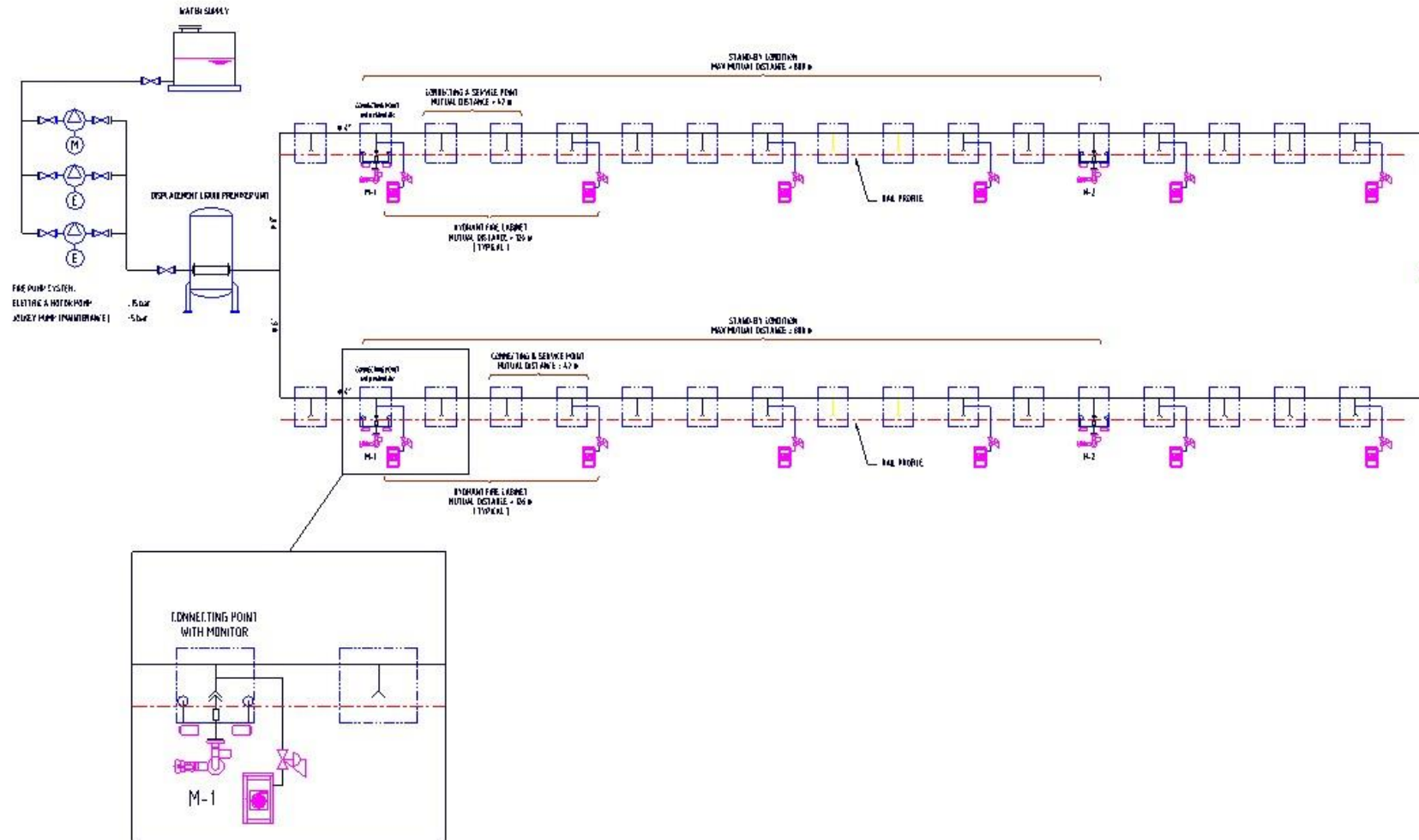

Dwg nr. MT001755

Typical water distribution of the system

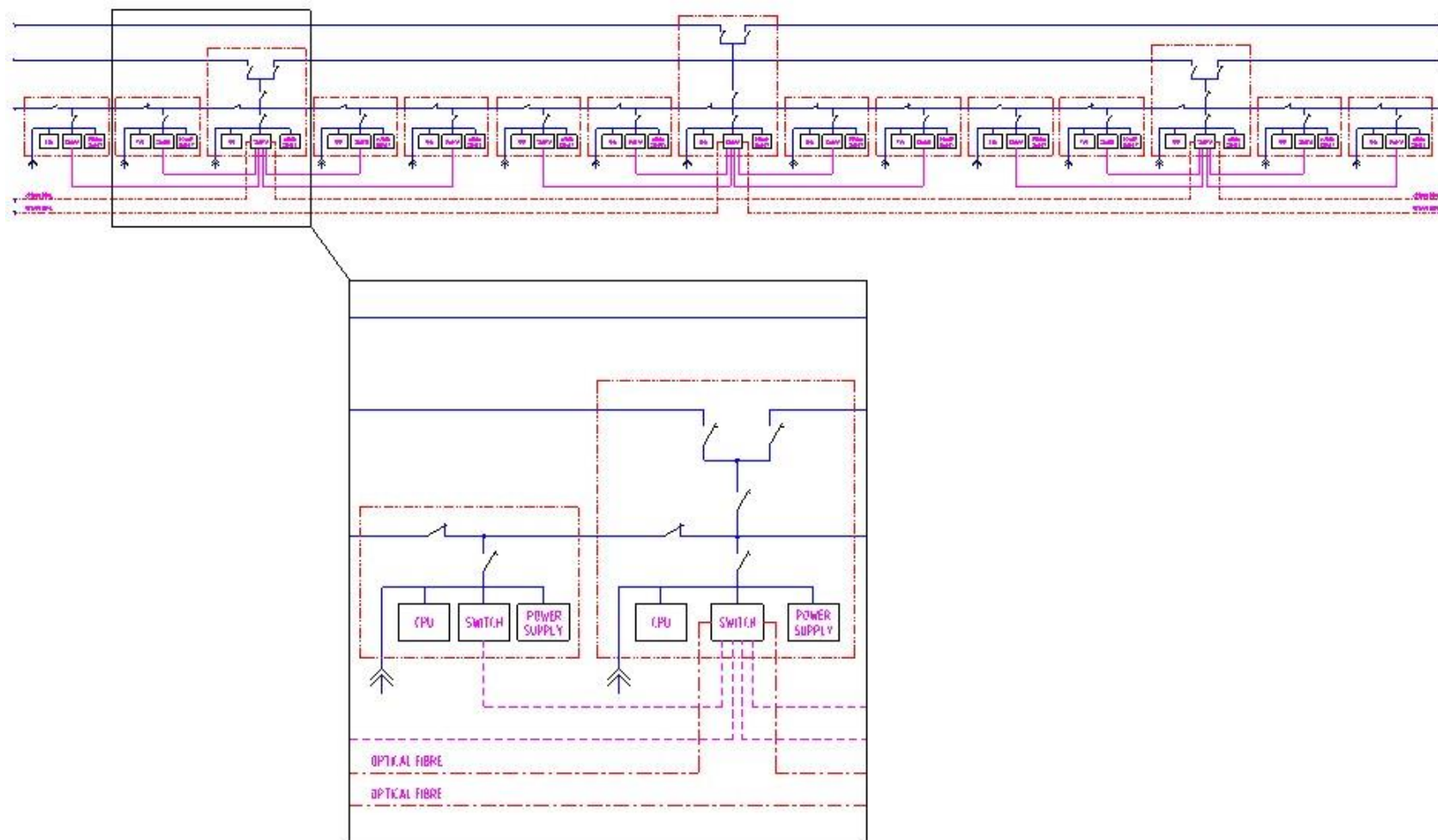

Dwg nr. MT011756

Typical double loop electric power and signal redundant connection diagram



Features of the fire extinguishing system for tunnel protection with mobile remote controlled monitors on overhead trailer and of the mobile units (overhead trailers)

The high performances and peculiar features of the fire extinguishing system for tunnel protection with mobile remote controlled monitors on overhead trailer and of the mobile units (overhead trailers) with monitor can be summarized as follows:

- compact dimensions for fitting in the available spaces of motorway and railway tunnels,
- possibility to be installed and to work in any position (horizontal, vertical, reclined) in the tunnel vault,
- high translation speed along the overhead rail,
- good acceleration and braking performances,
- low energy consumption for the movement along the overhead rail (to allow the transport on the mobile unit of the required stored energy),
- efficient energy storage system, with small dimensions and weight,
- high reliability of all functions,
- reasonable costs,
- self check and position identification along the overhead rail,
- specific design for operation with water and with foam.

System reliability

The world wide proven extinguishing capacity of the automatic fire fighting system with remote controlled monitors is combined with the highest reliability of its components, considering the particular conditions where the fire fighting intervention must be performed. To assure the highest reliability, redundancy has been applied to all critical parts of the system, for which not only the best materials and components available on the market have been selected, but also the most updated and reliable technology of monitoring, communication and check procedures have been adopted.

In particular for the data transmission a TCP/IP system has been selected, in order to allow the direct use of already existing communication structures or future structures to be realized for the remote transmission of alarms, commands and controls to the centralized Control Rooms of the tunnel without additional costs.

The system is therefore designed to be redundant in all its features:

- extinguishing operation by means of 2 monitors on the 2 sides of the fire (1 monitor is sufficient for extinguishing the fire),
- the monitors approach the fire from 2 different sides,
- the power supply of the docking and control stations is performed in a loop; therefore it is possible to supply separately and independently the 2 sides of any area involved in the fire,
- the data transmission (both via optical fibre and copper cable) is performed in a twin loop, separately and independently for the two sides of any area involved in the fire,
- the movement of the mobile unit along the overhead rail is assured by 4 driving wheels driven by 4 independent electric motors; the power of 2 motors is sufficient to move the trailer,
- the electric power connection and the signal connection between the docking and control stations and the mobile units are performed with 2 separate and independent plugs integrated in the special connecting couplings (one as operational reserve to the other),
- the data transmission (signals and commands) between each mobile unit and the Control Room is performed both with physical support (optical fibre + copper connection) and with wireless WiFi connection for high performances, suitable to transmit also the TV signals from the IP/TV cameras for visible and infrared light mounted on the mobile units.



Easy system installation

The automatic fire extinguishing system for tunnel protection with mobile remote controlled monitors on overhead trailer can be easily installed in new or in existing tunnels, without need to stop the tunnel traffic during the installation works of the system.

It can be installed in motorway tunnels, railway tunnels and in underground lines.

Maintenance

Like all fire protection systems (as required by law), the automatic fire extinguishing system for tunnel protection with remote controlled monitors needs periodical maintenance.

The rules require that all main and peripheral components of a fire protection system are subject to scheduled maintenance and periodical functional tests.

Maintenance activities on the system are particularly easy because:

- all system components are permanently monitored by the central control panel with immediate signalisation and record of any problem
- most of the components are mounted on mobile units or in the docking and control stations, so that the maintenance can be easily carried out without stopping the tunnel traffic.

Finally, no relevant pipe reductions or small size calibrated orifices are provided in the whole system, which items are particularly sensitive to impurities in the fire water and require special accurate maintenance interventions to assure their proper operation.

Applications of the system for ordinary monitoring and maintenance activities in the tunnel

Beside the main fire protection function, the automatic fire extinguishing system with mobile remote controlled monitors on overhead trailer can be utilized also for different purposes, such as monitoring and maintenance activities during the ordinary operation of the tunnel.

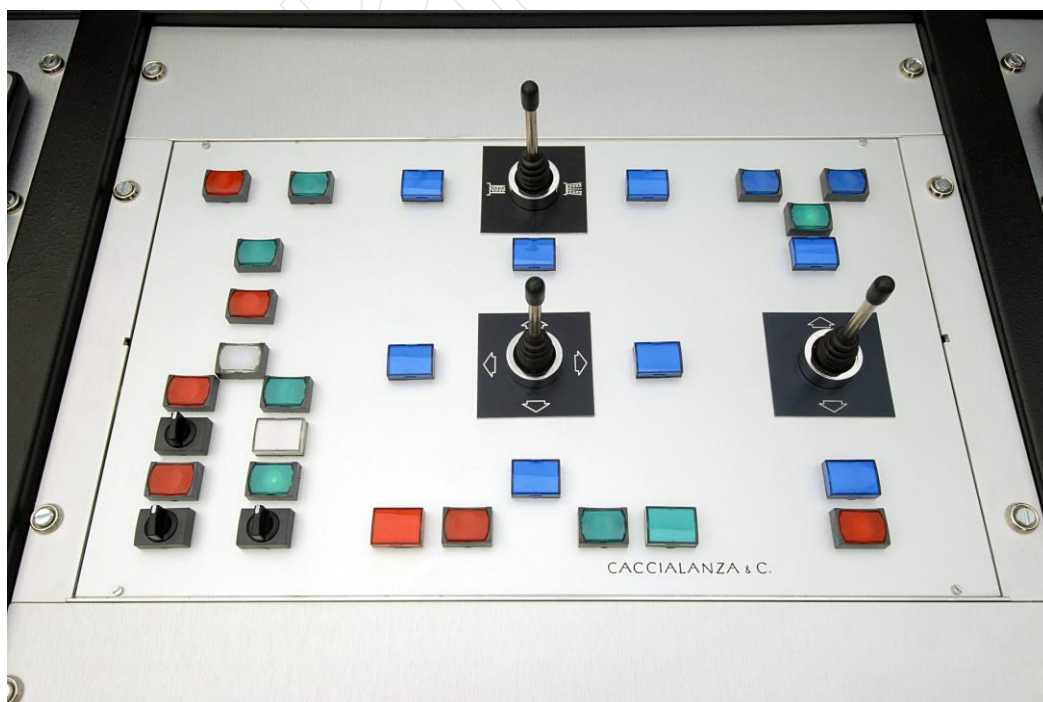



The mobile units equipped with IP / TV cameras for visible and infrared light can be moved along the tunnel to any docking and control station by means of the remote control system from the Control Room or, alternatively, additional fixed cameras can be mounted along the tunnel in proximity of the docking stations without any extra cost for signal transmission, feeding and management of these cameras, as such functions are already provided in the proposed fire extinguishing system.

The monitors can be used for cleaning activities (washing of the internal tunnel surfaces) or anti-pollution activities (dilution of dangerous liquids spills) by moving the overhead trailers wherever required along the tunnel by means of the remote control system and by spraying specific detergent or solvent liquids properly admixed to the water.

Both the docking and control stations and the mobile units can be equipped with sensors for check of the air pollution (CO, etc.) or for check of explosive atmospheres in the tunnel, for continuous working and monitoring both during ordinary traffic conditions and in emergency conditions.

The pictures in the tunnel show the extinguishing tests performed in the Test Tunnel of the Italian Fire Brigades' Training Centre in Montelibretti (Roma).

Caccialanza & C. reserve the right to change at any time, without prior notice, any specification or feature of the system in order to continuously improve the product.

The Automatic Extinguishing System for Tunnels with Remote Controlled Monitors on Overhead Rail is protected by the following Patents: Italian Patent MI2007A 000584 and MI2008A 000735,
International Patent PCT/EP2008/002153.